

Spoked handwheels with solid section

Technopolymer

MATERIAL

High-resilience polypropylene based (PP) technopolymer, black colour, matte finish.

Produced from FDA compliant raw material (FDA CFR.21 and EU 10/2011).

BOSS-CAP

AISI 304 stainless steel self-adhesive front plate adhesive suitable for contact with food (FDA CFR.21 and EU 10/2011).

STANDARD EXECUTIONS

AISI 304 stainless steel boss, H7 reamed hole.

- **VRTP-P+I-SST**: with revolving handle type I.621+x-SST in polyamide based (PA) technopolymer, certified in compliance with FDA.

- **VRTP-P+IR-SST**: with fold-away handle type IR.620 in polyamide based (PA) technopolymer, certified in compliance with FDA. AISI 304 stainless steel pin, bushing and internal components, AISI 316L stainless steel support.

- **K**: index for executions with hole and keyway in compliance with DIN 6885/1 (see page A16), tolerance P9 i.e.:

79111-R-K VRTP.80-P+I-SST-8-K

ACCESSORIES ON REQUEST

Axial retaining washer GN 184.5 (see page).

FEATURES AND APPLICATIONS

The solid rim of the handwheel allows the easy cleaning thanks to the absence of rear recesses. For this reason, being the technopolymer polypropylene based and the metal components in AISI 304 stainless steel, this version of VRTP. handwheel is designed for applications in food, pharmaceutical and medical fields.



ELESA Original design 1995 stuttgart

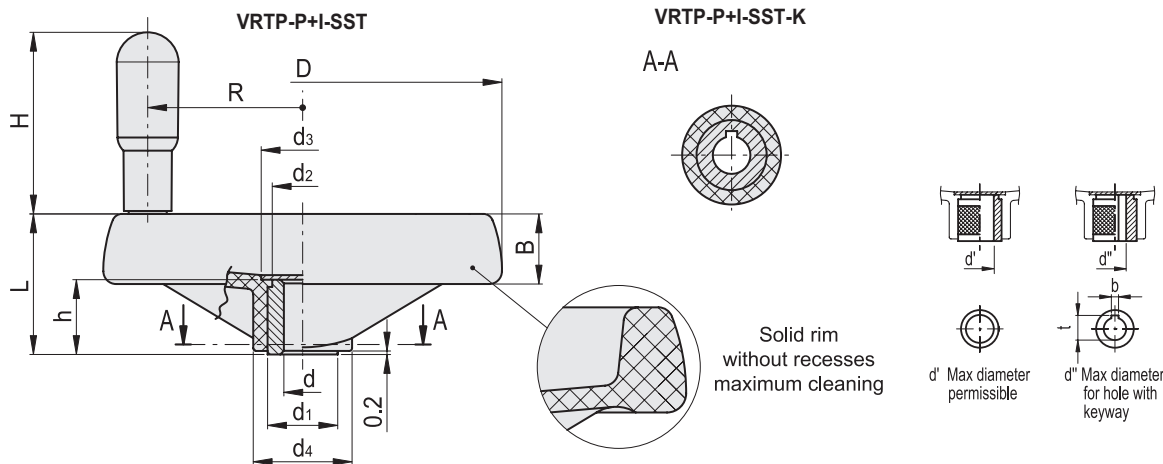

VRTP-P+I-SST

STAINLESS STEEL

Code	Description	D	dH7	L	B	d1	d2	d3	d4	h	H	R	d'	d''	t	b	C# [Nm]	L# [J]	⚖
79111-R	VRTP.80-P+I-SST-8	80	8	35	18	18	16	20.5	25	17	45	29	14	10	9	2	32	5	104
79161-R	VRTP.100-P+I-SST-10	99	10	37	20	18	16	20.5	25.5	17	60	37	14	10	11.4	3	54	7	145
79211-R	VRTP.125-P+I-SST-12	125	12	44	22	22	20	26	31	22	65	48	18	12	13.8	4	94	10	245
79261-R	VRTP.160-P+I-SST-14	160	14	51	25	26	24	32	40	27	73	65	20	16	16.3	5	185	15	356
79311-R	VRTP.200-P+I-SST-16	200	16	61	28	30	28	36	50	34	80	84	24	18	18.3	5	300	24	552
79313-R	VRTP.200-P+I-SST-20	200	20	61	28	30	28	36	50	34	80	84	24	22	22.8	6	300	24	548

* To order the execution with hole and keyway add the index -K after the code and description (i.e. 79111-R-K VRTP.80-P+I-SST-8-K).

For maximum applicable torque (C) and impact strength (L) see Technical Data on page A3.

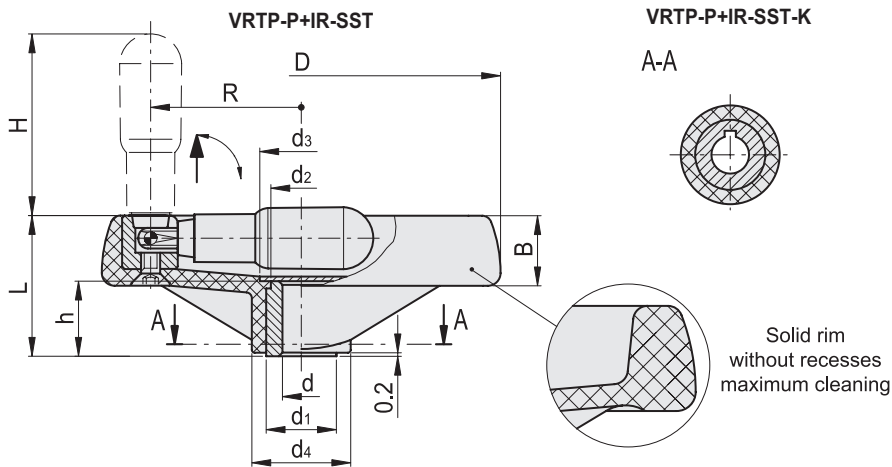

VRTP-P+IR-SST

STAINLESS STEEL

Code	Description	D	dh7	L	B	d1	d2	d3	d4	h	H	R	d'	d''	t	b	C# [Nm]	L# [J]	⚖
79121-R	VRTP.80-P+IR-SST-8	80	8	35	18	18	16	20.5	25	17	45	29	14	10	9	2	32	5	102
79171-R	VRTP.100-P+IR-SST-10	99	10	37	20	18	16	20.5	25.5	17	60	37	14	10	11.4	3	54	7	163
79221-R	VRTP.125-P+IR-SST-12	125	12	44	22	22	20	26	31	22	65	48	18	12	13.8	4	94	10	230
79271-R	VRTP.160-P+IR-SST-14	160	14	51	25	26	24	31	40	27	73	65	20	16	16.3	5	185	15	388
79321-R	VRTP.200-P+IR-SST-16	200	16	61	28	30	28	36	50	34	80	84	24	18	18.3	5	300	24	593
79323-R	VRTP.200-P+IR-SST-20	200	20	61	28	30	28	36	50	34	80	84	24	22	22.8	6	300	24	588

* To order the execution with hole and keyway add the index -K after the code and description (i.e. 79111-R-K VRTP.80-P+I-SST-8-K).

For maximum applicable torque (C) and impact strength (L) see Technical Data on page A3.

